

31" 4K Medical Display

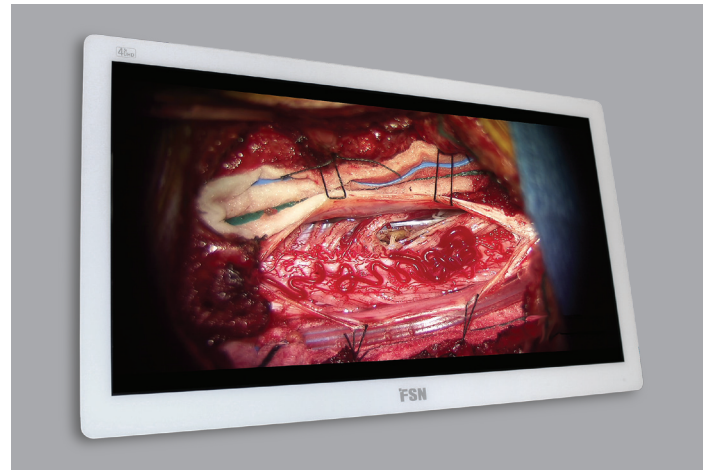

FSN Medical Technologies has developed solutions for displaying crystal clear 4K video. This cutting-edge technology has been engineered for medical visualization applications to allow surgeons to see live video images with incredible resolution. It allows the doctor to view intricate hand movements on-screen, and control medical visual content with pinpoint accuracy. FS-P3102D and FS-P3102DS can fine-tune surgical color and layout settings to individual preferences.

- 4K (4096 x 2160 pixels), at 60 Hz, in the surgical suite
- Bonded front filter for higher brightness and contrast ratio
- State-of-the-art surgical visualization, the best possible image
- Ready, out of the box, for advanced digital OR installations
- Flush-front glass surface, fast and easy to clean
- Slim profile and narrow bezel for a streamlined design

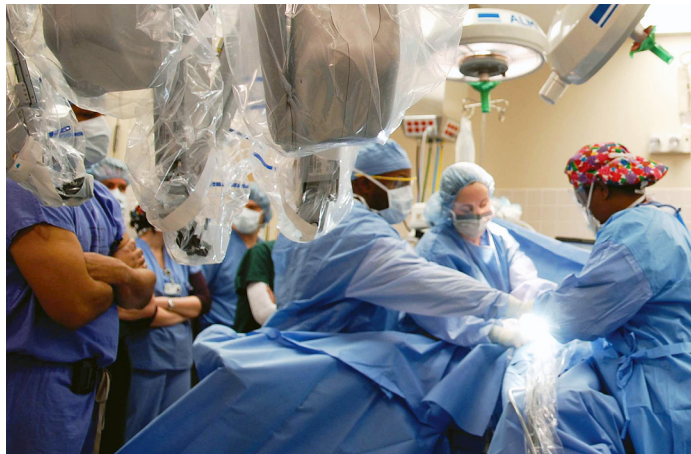

FSN's 31" 4K display features signal input options for HDMI, DVI, DisplayPort, and SDI (FS-P3102DS), plus DC out power for smaller components. With a slim, sleek design and a flush-front glass bezel, FS-P3102D is ideal for showing super-sharp 4K images, and mounting to most OR boom arm systems.

Accurate Color Reproduction

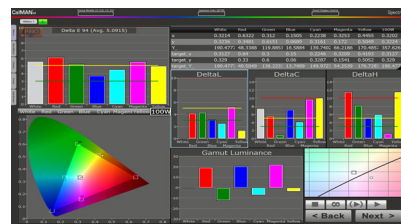

FSN has implemented methods to fine-tune the properties of our displays. Distinct color space settings have been calibrated to well-known surgical color preferences.

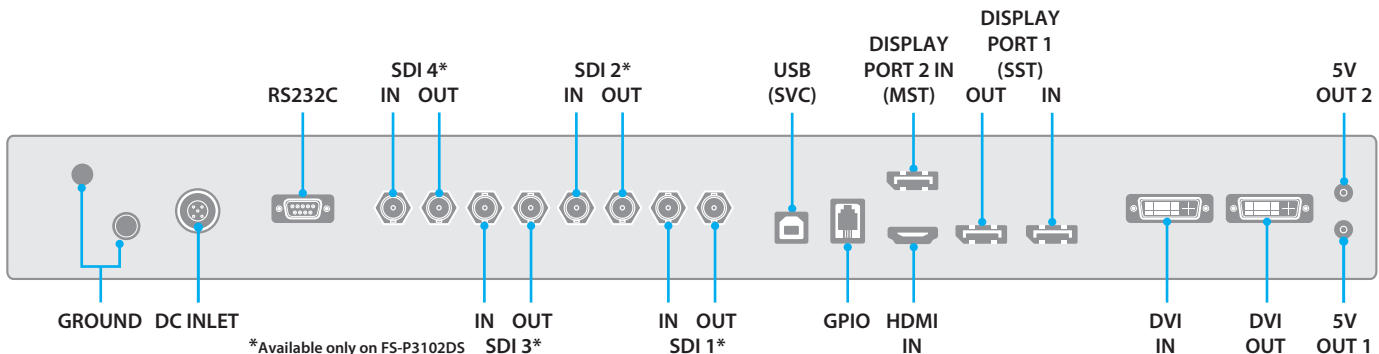

*Available only on FS-P3102DS
 FSN displays have the connections you need. Video and communication signals are connected to the monitor's back panel.

Specifications

General Features

Item	Description
Panel	31 inch TFT LCD (LED)
Resolution	4096 x 2160 pixel
Aspect Ratio	17 : 9
Active Area	697.96 X 368.06 mm
Input Signal	1 x HDMI 2.0 1 x DP 1.2 (MST) 1 x DP 1.2 (SST) 1 x DVI (Single Link) 4 x SDI (3G) (Available only on FS-P3102DS)
Output Signal	1 x DVI (Single Link) 1 x DP 1.2 (SST) 4 x SDI (3G) (Available only on FS-P3102DS)
Power Supply	AC/DC Adaptor (AC 100~240V, DC 24V 6.6A)
Control Key (touch)	Power, Menu, PIP, Up, Down, Plus, Minus, Input

Item	Description
Unit Dimension	761.5(W) x 442.0(H) x 70.6(D) mm 29.98(W) x 17.40(H) x 2.79(D) inch
Average Brightness	350 cd/m ²
Response Time	11 ms (typical rise time)
Viewing Angle (CR>10)	R/L 178, U/D 178
Weight	FS-P3102D: 9.24 kg, 20.37 lbs. FS-P3102DS: 9.6 kg, 21.16 lbs.
Contrast Ratio	1500 : 1 typical
Pixel Pitch (mm)	0.1704 x 0.1704
IP Rating	IP33 - overall, IP44 - front side only
IK Rating	IK07 with 5H AR glass

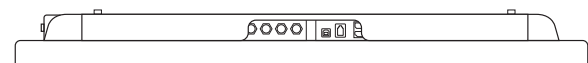
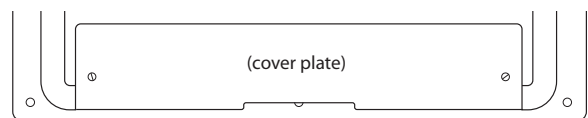
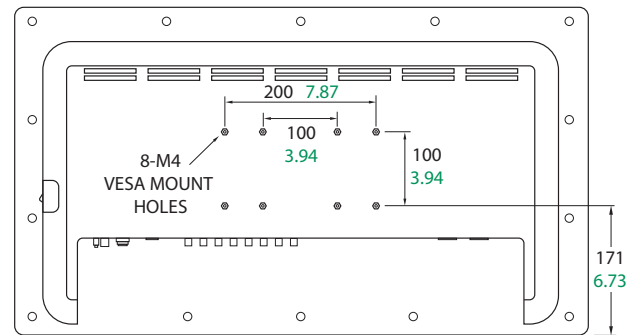

FSN has developed a process, seeking to improve picture quality, and applied it to FS-P3102D and FS-P3102DS. These LCD panels use enhanced bonding technology and show an improvement in contrast ratio and brightness, plus improved humidity resistance and breakage resistance.

Bonding technology and show an improvement in contrast ratio and brightness, plus improved humidity resistance and breakage resistance.

Specifications are subject to change with or without notice. Doc. # FSN1984 Rev. 7/17