

24" HD LED Medical Display

Detect subtle variations in surgical site tissue with motion adaptive deinterlacing and advanced 3D noise reduction. State-of-the-art technology is built into FSN display monitors, ensuring forward compatibility with future video signal standards. FS-L2402D satisfies integrated OR requirements for patient safety, reliability, precision, HD digital images, and unique space requirements.

- **Higher brightness and contrast - 600 nits**
- Designed and manufactured to FSN's strict quality standards
- Approved as medical electrical equipment
- Easy to install
- Lightweight to meet boom and spring-arm weight requirements
- Dependable service record in the field
- Calibrated at the factory for optimum HD color and resolution
- Perfect for dual-monitor requirements
- Compliant to safety standards

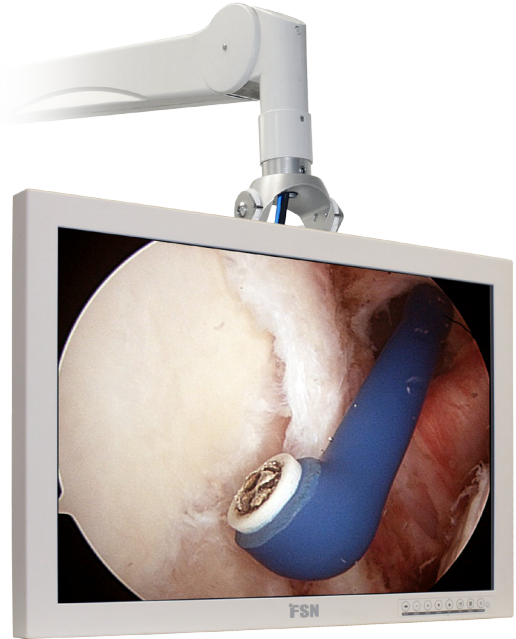

The input/output options on FS-L2402D include dual DVI, plus an on-board DC out power connection for smaller component needs. Like all FSN displays, it features rapid signal detection of video sources found in the OR, and can satisfy the need for smooth, artifact-free medical images.

Accurate Color Reproduction

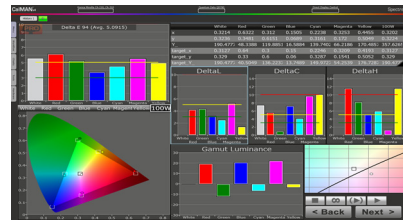

FSN has implemented methods to fine-tune the properties of our displays. Distinct color space settings have been calibrated to well-known surgical color preferences.

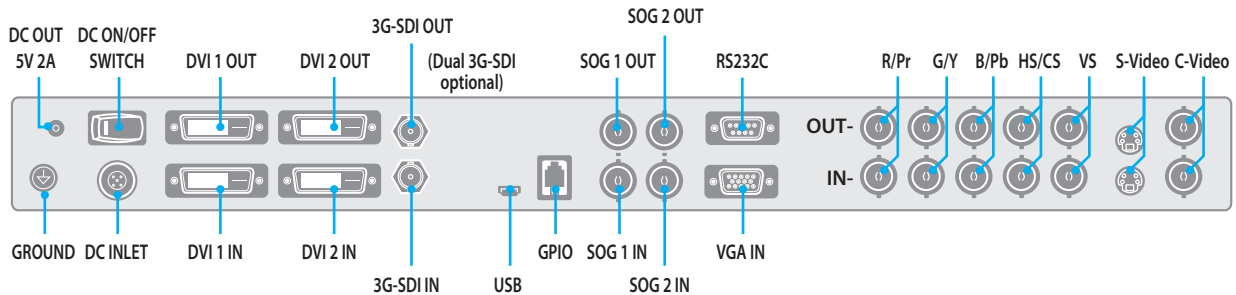

FSN displays have the connections you need. All major inputs are accepted via the back side connection panel.

Specifications

General Features

Item	Description
Panel	24 inch TFT LCD (LED)
Resolution	1920 x 1200 pixel (WUXGA)
Aspect Ratio	16 : 10
Active Area	518.4 (W) X 324.0 (H) (mm)
Input Signal	2 x DVI-D 1 x SD/HD/3G-SDI (BNC) (2 x SDI optional) 2 x SOG 1 x VGA (D-sub) 1 x C-Video (BNC) 1 x S-Video (DIN) 1 x Component (RGBS, YPbPr) (5 x BNC)
Output Signal	2 x DVI-D 1 x SD/HD/3G-SDI (BNC) (2 x SDI optional) 2 x SOG 1 x C-Video (BNC) 1 x S-Video (DIN) 1 x Component (RGBS, YPbPr) (5 x BNC)
GPIO Port	Swap, PIP / PBP1 / PBP2 Select, Record indicator
External Control	RS232 Control
Power Supply	AC/DC Adaptor (AC 100-240V~, DC 24V 6.25A)
Control Key	Power, Menu, PIP, Up, Down, Plus, Minus, Input
Unit Dimension	580 (W) x 386 (H) x 70 (D) mm 22.84 (W) x 15.20 (H) x 2.76 (D) inch
Weight	7.5 kg, 16.53 lbs
Pixel Pitch	0.27 (W) x 0.27 (H)
Contrast Ratio	1000 : 1 typical
Viewing Angle (CR>10)	R/L 178, U/D 178
Response Time (G-to-G)	14 ms (avg.)
Surface Luminance	600 (5 points avg.) cd/m ²

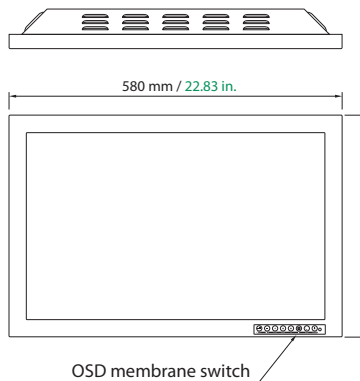

Output Signal Timing

Signal	Type	Description
Component Video	Type	Analog Y/G, Pb/B, Pr/R
	Connector	BNC
	Level	0.7Vp-p ±5% (1.0Vp-p for sync embedded G/Y)
	Polarity	Positive
	Impedance	75 ohm ±5%
	Horizontal frequency	30 ~ 93KHz
	Vertical frequency	50 ~ 85Hz
	Applicable max. pixel frequency	170MHz
	Maximum resolution	1920x1080 / 60Hz (148.5MHz Timing, NON-CRT)
	Component Sync	Type
Level		TTL Level (V high ≥2.0V, V low ≤0.8V)
Polarity		Positive or Negative
Connector		BNC
SOG	Type	Sync on green
	Level	0.7Vp-p ±5%
	Impedance	75 ohm ±5%
DVI	Max. resolution	1920x1200 / 60Hz (154MHz Timing, NON-CRT)
	Connector	BNC
	Type	Digital RGB
C-Video	Signal Format	TMDS single link
	Connector	DVI-D
	Type	C-Video
S-Video	Color system	NTSC, PAL
	Connector	BNC
	Type	S-Video
SDI	Color system	NTSC, PAL
	Connector	mini-DIN
	Type	SMPTE-424M 1080p SMPTE-292M 720p, 1080i SMPTE-259M 480i, 576i

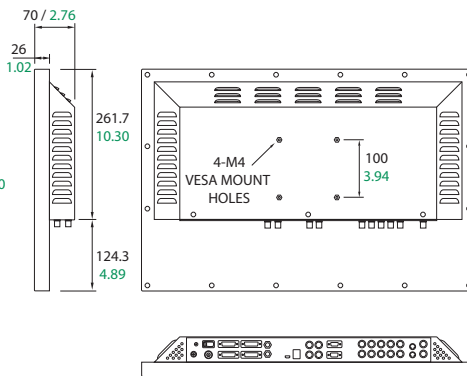

Input Signal Timing

Signal	Type	Description
VGA, Component Video	Type	Analog RGB, Analog YPbPr
	Connector	DSUB-15 (VGA), BNS (Component)
	Level	0.7Vp-p ±5% (1.0Vp-p for sync embedded G/Y)
	Polarity	Positive
	Impedance	75 ohm ±5%
	Horizontal frequency	30 ~ 93KHz
	Vertical frequency	50 ~ 85Hz
	Applicable max. pixel frequency	170MHz
	Max. resolution	1920x1200 / 60Hz (154MHz Timing, NON-CRT)
	Type	Separate H/V Sync, Composite Sync. Automatic synchronization without external switch
VGA, Component Sync	Level	TTL Level (V high ≥2.0V, V low ≤0.8V)
	Polarity	Positive or Negative
	Range	Automatic synchronization for applicable resolution modes which follows industrial standard within frequency range of 30 to 93KHz in horizontal and 50 to 85Hz in vertical
	Terminal resistance	more than 2KΩ
SOG	Type	Sync on green
	Level	0.7Vp-p ±5%
	Impedance	75 ohm ±5%
DVI	Maximum resolution	1920x1200 / 60Hz (154MHz Timing, NON-CRT)
	Connector	BNC
	Type	Digital RGB
C-Video	Signal Format	TMDS single link
	Connector	DVI-D
	Type	Analog Composite Video
S-Video	Color system	NTSC, PAL
	Connector	BNC
	Type	Analog Y/C Separated Video
SDI	Color system	NTSC, PAL
	Connector	mini-DIN
	Type	SMPTE-424M 1080p SMPTE-292M 720p, 1080i SMPTE-259M 480i, 576i

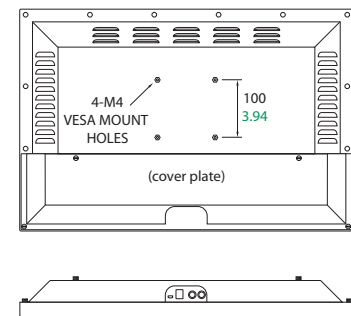

Specifications are subject to change with or without notice. Doc. # FSN1953 Rev. 9/15