

SYSTEM TWO
MH SERIES

Bovie[®]

SYSTEM TWO
MH Series

HIGH INTENSITY DISCHARGE SURGERY LIGHTING



EFFICIENT

The SYSTEM TWO MH Series by Medical Illumination International harolds a notable increase in lighting efficiency

BRIGHT

The System Two MH Series produces over 100,000 Lux (9,500 foot candles) at 1 meter using a 39 Watt Metal Halide bulb

COOL

Uniquely engineered H.I.D. bulb virtually eliminates heat

CLEAR

Multi-faceted reflector increases shadow reduction for positioning flexibility during exam and procedure

VERSATILE

Four-Stage dimming, a variety of mounting styles and an optional video or monitor, offer the ultimate degree of office and surgery room capability

LOW MAINTENANCE

The 10,000 hour bulb is effortlessly changed in under a minute

RELIABILITY



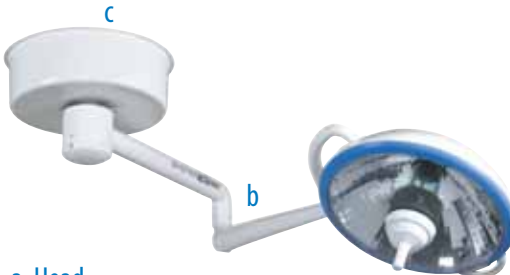
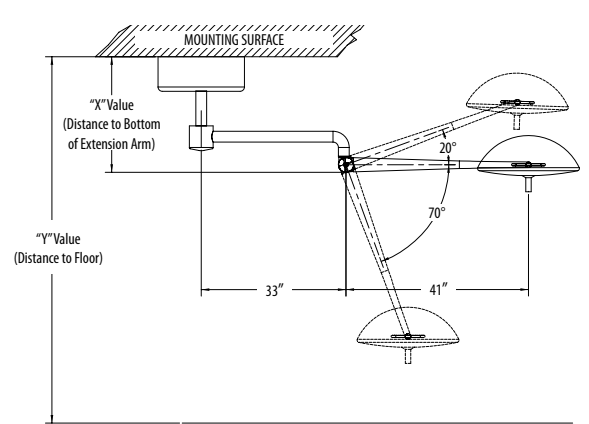

The System Two MH Series is backed by a three (3) year manufacturer's limited warranty

SURGICAL LIGHTING

SYSTEM TWO
MH SERIES
INCLUDES

Solo Ceiling Mount Model	Rotation and Arm Movement
 <p>a. Head b. Articulating Arm c. Single Ceiling Mount</p> <p>S2SMH</p>	

OTHER SYSTEM TWO
MH MODELS
AVAILABLE

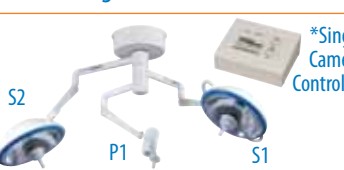
Wall Mount Model	Duo Ceiling Model	Portable Floor Model
 <p>S2MHWM</p>	 <p>S2DMH</p>	 <p>S2MHFM</p>
 <p>S2MHWM-MA</p>	 <p>S2TMH-VC *Controller included with Video Camera</p>	

TECHNICAL SPECIFICATIONS
SYSTEM TWO
MH SERIES

Dimensions: Solo Surgery Head		Rotations:	
Ceiling casting	17.0" (431.8 mm) Dia. x 4.7" (119.4 mm) deep	Ceiling mount/extension arm interface	Continuous
Ceiling rod	Available for mounting heights from 8'-12' (Above 10' at additional cost)	Articulating/extension arm interface	Continuous
Arm Assembly	(to center of light-head) 74" (1,880 mm)	Articulating arm vertical movement	+20, -70 Degrees
Light head assembly	23.0" (584.2 mm) diameter x 10.0" (254 mm) deep	Articulating arm/Yoke interface	Continuous
		Yoke/lamp head interface	+/- 150 Degrees
Weight:		Data:	
Solo ceiling mount assembly	Approximately 73.5 lbs (33.3 Kg)	Light Source	MH (High Intensity Discharge)
Duo ceiling mount assembly	Approximately 104.5 lbs (47.4 Kg)	Bulb Life in Hours	10,000 hours (average) For Primary
Trio ceiling mount assembly	Approximately 155.5 lbs (70.5 Kg)	Color Temperature	4300 Kelvin
Light head assembly	Approximately 23.5 lbs (10.7 Kg)	Lux	100,000 Lux* (9,500 foot candles*)
		Input Voltage	100 - 125 VAC

For more product information, contact your Bovie sales representative.

 Made in the USA. The SYSTEM TWO MH Series is currently only available for sale in the USA.

